

## > We are DEVELON

We trace our roots to 1937 as one of Korea's first large scale machine plant. Throughout time we have consistently delivered exceptional products and solutions.

DEVELON is a bold name that reflects our core ambition to continue developing onwards and leaving behind a positive footprint in our world. Moving forward, we seek to be part of our customers and partners' endeavor to build a better world.

Powered by **Innovation**



©2024 HD Hyundai Infracore. All rights reserved.  
HDIPBE-01-2403

Certain specification(s) are based on engineering calculations and are not actual measurements. Specification(s) are provided for comparison purposes only and are subject to change without notice. Specification(s) for your individual Develon equipment will vary based on normal variations in design, manufacturing, operating conditions, and other factors. Pictures of Develon units may show other than standard equipment.

[develon-ce.com](http://develon-ce.com)

# DEVELON

Excavators

## DX1000LC-7 (T3)



Photos may include optional equipment.

# DO BIG JOBS BETTER WITH FORCE



The DX1000LC-7 is designed for maximum productivity with outstanding performance, durability and surprisingly high fuel efficiency. Serving as your reliable partner, it will enable you to work in harsh mining environments where avoiding downtime is critical.

# OVERVIEW OF DX1000LC-7

## HIGH PRODUCTIVITY WITH LOW COST OF OWNERSHIP

Delivers higher productivity and reduced fuel consumption for efficient and comfortable work environment.

## OPERATION AT EASE

- All important information is at your fingertips with the new easy-to-use 8" touch screen.
- Exclusive jog shuttle switch for 4 working mode and 4 power mode.

## RELIABILITY

Designed for the toughest applications and the most abrasive environment.

## SAFETY

Your safety is our priority.

- Around View Monitoring system (OPTIONAL)
- Large side mirrors
- Powerful LED work lights
- Anti-slip steps and platforms, guard rails on upper structure

## MASS EXCAVATION

2 Heavy duty(HD) front combinations available to match various conditions. Mass excavation front with large bucket size or heavy-duty fronts when long reach is needed.

## SWING BEARINGS

Unique design of crossed bearing providing longer lifetime with lower stress distribution.



## EASY MAINTENANCE

Automatic greasing system as an option, all filters easily accessible, compressor with air gun as option, everything designed for easy maintenance.

## COMFORT

One of the most spacious cabs in the market, with low noise & vibration levels and excellent all-round visibility. Fully adjustable heated air-suspension seat, air conditioning with climate control as standard.

## UNDERCARRIAGE DURABILITY

Heavy-duty undercarriage, with large rollers and sprocket, enhanced frame for the toughest applications.

## ENGINE

Exceptionally powerful – with high torque at low revs – the Perkins 2806D engine combines reliability and low environmental impact. This T3 compliant 6 cylinder engine delivers 470 kW @ 2,100rpm.

## EXCELLENT FUEL EFFICIENCY

The Smart Power Control (SPC) system increases fuel efficiency by adjusting the power to meet the application's needs.

## ADVANCED FILTRATION

High efficiency filters & cleaners remove water, dust & particles to protect your investment optimally.



# PERFORMANCE AND PRODUCTIVITY

New and Intelligent Hydraulic System Delivers The Best-In-Class Productivity.

**18%**  
HIGHER  
PRODUCTIVITY

Internal test result vs. DX800LC  
(Maximum size bucket)

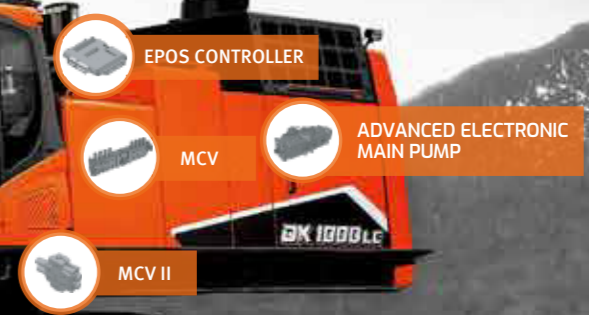

\* Actual product may differ from the image shown above.

## ENGINE WITH ENHANCED POWER AND RELIABILITY

Manufactured in a world-class facility for reliability and durability, the DX1000LC-7 engine ensures many years of productive life to keep your machine running efficiently and effectively even under the toughest jobsite conditions. Along with this, it allows you to maintain your machine at a low cost throughout its lifetime with features that minimize service costs combined with low fluid consumption.



## THE MOST ADVANCED HYDRAULIC SYSTEM (D-ECOPOWER+)

This new electronic main pump accurately calculates the amount of pump flow required for each actuator, thereby maximizing productivity (faster operation) and avoiding unnecessary fuel loss.

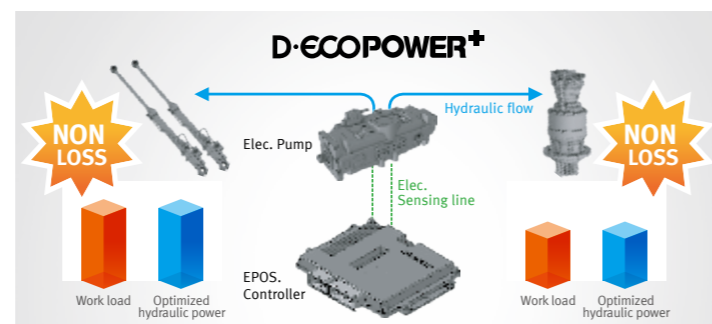

## SELECTABLE OPERATING MODES OPTIMIZED FOR VARIOUS WORK ENVIRONMENTS

Boom/Swing priority control allows you to control operating modes with just one button and provides optimized level, resulting in a more comfortable and productive operation.

### BOOM PRIORITY MODE

Hydraulic power

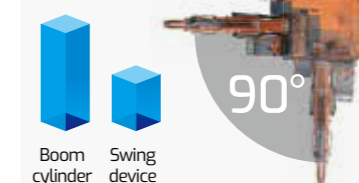

### SWING PRIORITY MODE

Hydraulic power



## EFFICIENT FUEL MANAGEMENT

- Choice of 4 power modes and 4 working modes offers optimum performance in all conditions.
- Smart Power Control (SPC) system: provides optimal engine speed and pump torque according to work conditions. The system automatically adjusts engine power and hydraulic output to improve fuel efficiency and reduce emissions.
- Engine auto-shut-off: shuts down the engine after the machine has been idling for a specified time. The operator can set the delay before shut-off via the touchscreen.



# INCOMPARABLE DURABILITY

Built With Quality-Proven Main Components And Durable Design For Minimized Downtime

## QUALITY-PROVEN MAIN COMPONENTS

Manufactured with the finest quality main components customized precisely for large equipment, this new machine offers the Best-in-Class power and durability.



A. SWING MOTOR



B. MCV

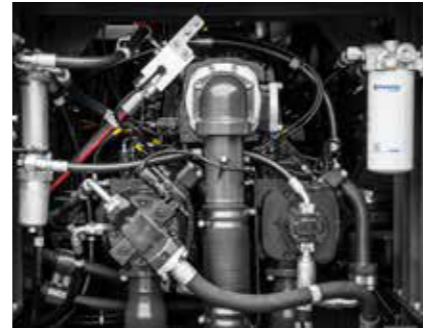

C. MAIN PUMP



PROTECTED HYDRAULIC SYSTEM



D. ENGINE

\* Actual product may differ from the image shown above.

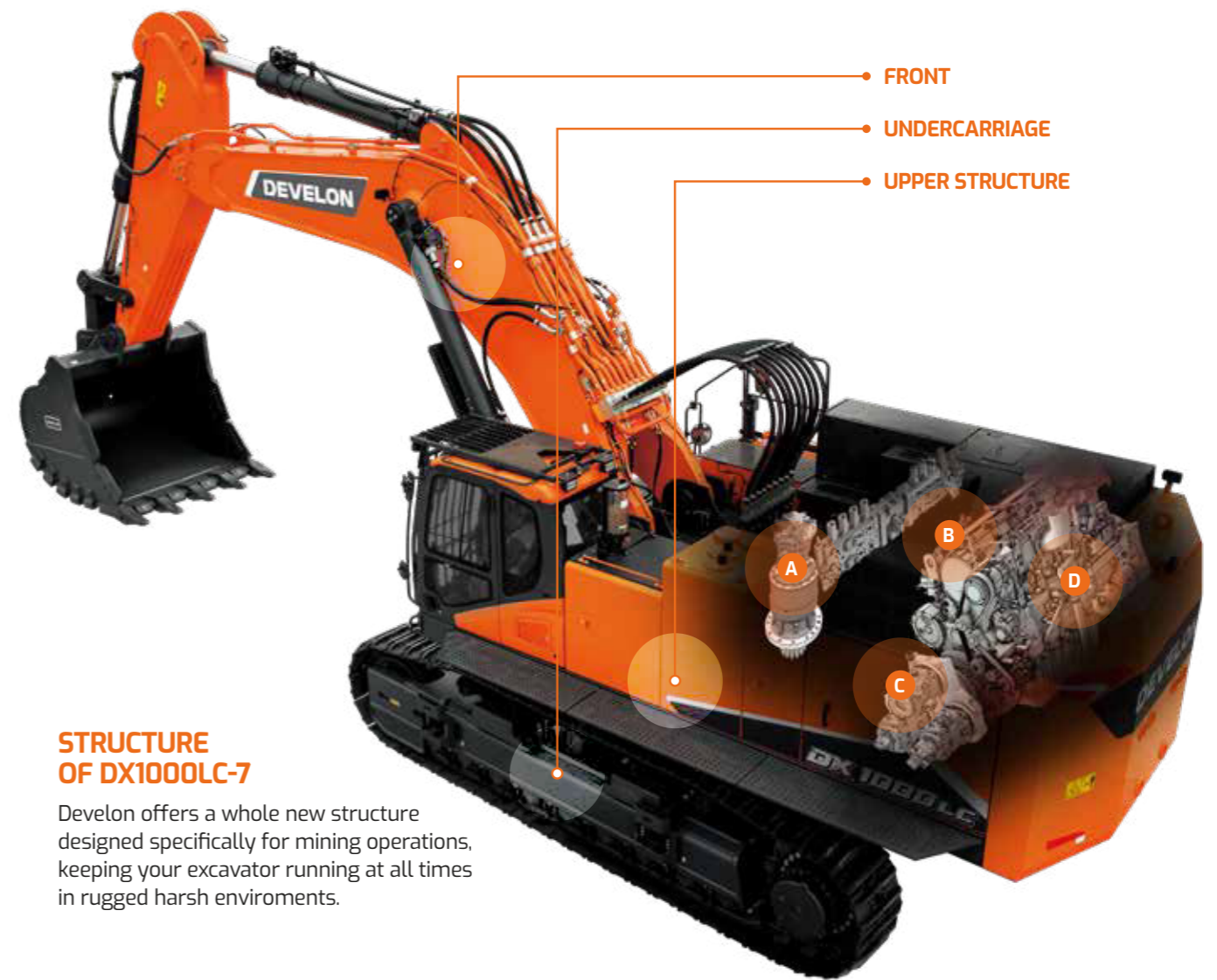

## STRUCTURE OF DX1000LC-7

Develon offers a whole new structure designed specifically for mining operations, keeping your excavator running at all times in rugged harsh environments.

## HEAVY DUTY FRONT

Performance of the boom and arm of the DX1000LC-7 has considerably enhanced the overall durability of the machine.

### BOOM

- Boom foot design to increase the pin strength and decrease one-side wear of pin.
- Flat steel plate for dispersing machine stress.
- Welding design to increase welding part lifetime.
- Inner reinforce plate changed for dispersing stress.

### ARM

- Bottom steel plate of arm to increase strength of arm structure.
- Arm center boss to lower stress.
- Arm welding design to decrease stress.
- Diameter of pin (130 ▶ 140) to increase pin strength.

## UPPER STRUCTURE



HEAVY DUTY UNDER COVER



CROSSED ROLLER SWING BEARINGS

Unique design of crossed bearing providing longer lifetime with lower stress distribution.

## UNDERCARRIAGE



FRAME



UNDERCARRIAGE

Our heavy duty undercarriage further increases durability of your machine.



HEAVY-DUTY SPROCKET

Our heavy duty sprocket further increases durability of your machine.

# COMFORT AND SAFETY

Safety Comes In First With Enhanced Safety Features



## LED WORKING LAMP (OPTIONAL)

More productive at night with highly improved sight.



## AROUND VIEW MONITOR (AVM) SYSTEM (OPTIONAL)

Provides 360-degree view in your cabin through AVM system.



## 8" TOUCH SCREEN

An easy to read and use 8" touch screen integrated all function in one place

## DEVELON SMART KEY

We bring automotive standard and comfort to construction machinery

- Search function
- Coming/leaving home light function
- Remote door opening
- Keyless engine start



## ERGONOMICALLY DESIGNED PEDAL

Ergonomically designed pedals placed in the middle. Pedal angle adjusted to relieve the pressure on ankle and joints, reducing fatigue of operator.



# EASY MAINTENANCE

We Offer Easy, Breezy Maintenance System That Can Also Prevent Downtime Of Your Machine.



**HEAVY DUTY AIR CLEANER**  
Protects from dust and contaminated particles with a two-stage air cleaner, enabling easy maintenance and downtime avoidance.

**REVERSIBLE FAN**  
- Rotating cooling fan in reverse direction is possible.  
- Able to blow away dust on radiator and oil cooler easily to save time & effort.

**AUTO GREASE SYSTEM (AGS)**  
This new auto grease filling device helps reduce maintenance time significantly and avoid unexpected downtime.

**ELECTRIC FUEL TRANSFER PUMP (ETP)**  
Use this switch to easily refill fuel for your machine after its inspection or repair.

**CENTRALIZED FUEL FILTRATION SYSTEM**  
Water separator, pre-fuel filter and main filter are grouped together to increase engine life and prevent machine failures, making machine inspection or maintenance much easier with one simple access.

**AIR COMPRESSOR**  
Air gun in your cabin helps you to keep clean and comfortable ambience.

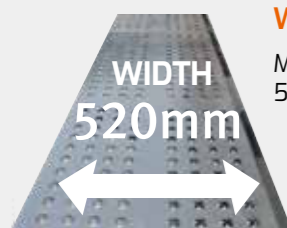

**WIDE CATWALK**  
Maintenance becomes easy with 520mm catwalk.

\* Actual product may differ from the image shown above.

# DEVELON FLEET MANAGEMENT

## Telematics Service (OPTIONAL)

**TELECOMMUNICATIONS** Data flow from machine to web



### TELEMATICS TERMINAL

Terminal device is installed and connected to a machine to get machine data.

### TELECOMMUNICATION

DEVELON provides Dual mode (Cellular, Satellite) communication to maximize communication coverage

### DEVELON FM WEB

User can monitor machine status from DEVELON FM Web

**TELEMATICS SERVICE BENEFITS** Develon and dealer support customers to improve work efficiency with timely and responsive services

#### CUSTOMER

Improve work efficiency

- Timely and preventive service
- Improve operator's skills by comparing work pattern
- Manage fleet more effectively

#### DEALER

Better service for customers

- Provide better quality of service
- Maintain machine value
- Better understanding of market needs

#### DEVELON

Responsive to customer's voice

- Utilize quality-related field data
- Apply customer's usage profile to developing new machine

**FUNCTIONS (WEB/APP)** Develon Telematics Service provides various functions to support your great performance



- GPS
- Fuel information
- Preventive maintenance
- Operation hours



- Fault code / warning
- ADT Productivity
- Reports

FUNCTION	EXCAVATOR	WHEEL LOADER	ADT
GPS	All models	All models	All models
Operation hours	All models	All models	All models
Maintenance parts	All models	All models	All models
Fault code / Warning	All models	All models	All models
Fuel information	All models	All models	All models
Dump capacity	N/A	N/A	All models

# GLOBAL PARTS NETWORK

## QUALITY-PROVEN MAIN COMPONENTS

Develon provides fast and precise worldwide delivery of genuine Develon parts through its global PDC (parts distribution center) network.



## GLOBAL NETWORK

The global network of the GPDC (Global Parts Distribution Center) maximizes its fill rate by making sure that each center is stockpiled with all the critical parts required for businesses in its area. The network also minimizes the time and costs required for parts delivery by positioning PDCs close to major markets around the world. Develon PDCs communicate with customers in their time zone, informing them that they are open for operation, and deliver parts to them as early as possible.

## THE GLOBAL PARTS DISTRIBUTION CENTER NETWORK

PDCs had been set up as shown below, including Mother PDC in Ansan, Korea. The ten other PDCs include one in China (Yantai), three in USA (Atlanta, Seattle and Miami), two in Europe (Germany and the UK), one in the Middle East (Dubai), two in Asia (Singapore and Indonesia) and one in Brazil (São Paulo).

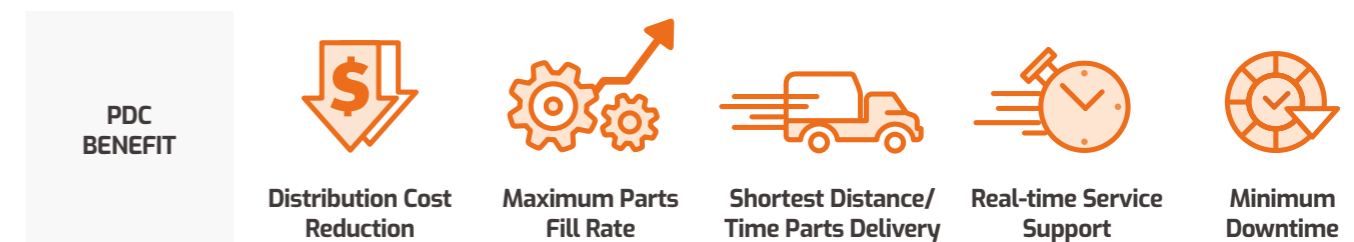

# ATTACHMENTS

## ESD SERIES BUCKET (SEVERE DUTY)

Designed for mainly focusing on breaking job. Develon's focus is to optimize impact power, enhance durability, satisfy customer convenience and maintain easily in order to be faithful to the original function of hydraulic breaker.



### Feature & Benefits

- High abrasion resistant steels are applied for superior durability.  
400HB: Equivalent to Hadox400  
500HB: Equivalent to Hadox500 or Borox500
- Optimized design for Develon genuine SD tooth for high penetration.
- Bolt-on shroud protectors.
- Strong wear pad on bottom.
- Dual curved profile for high productivity.
- Low tip radius for greater digging performance.

■ High strength steel ■ High abrasion resistant steel (400HB) ■ High abrasion resistant steel (500HB)

Classification	Model name	Width(mm)	Capacity(m <sup>3</sup> )	width(mm)
ESD100-2000	230104-05765	2040	5.4	2040
ESD100-2400	230104-05742	2420	6.8	2420

## HYDRAULIC BREAKER



### Feature & Benefits

- Cover all Develon equipments from small to super heavy sized.
- Reliable Performance certified by AEM.
- 3D based design and analysis to optimize structure.
- Standard option for Dual Speed Control system & Anti-Blank Blow
- Centralized auto grease system (Optional)
- Underwater operating Kit (Optional)
- 2 years Warranty

Model name	Weight (Kg)	Operating Pressure (bar)	Oil Flow (l/min)	Impact rate (bpm)	Chisel type
XB90	8,466	150 ~ 185	380 ~ 480	335 ~ 425	MOIL
	8474.7	150 ~ 185	380 ~ 480	335 ~ 425	MOIL(AGS)
	8,466	150 ~ 185	380 ~ 480	335 ~ 425	WEDGE(H)

# SPECIAL APPLICATION

Develon provide various solution & various custom job application.

## MATERIAL HANDLER

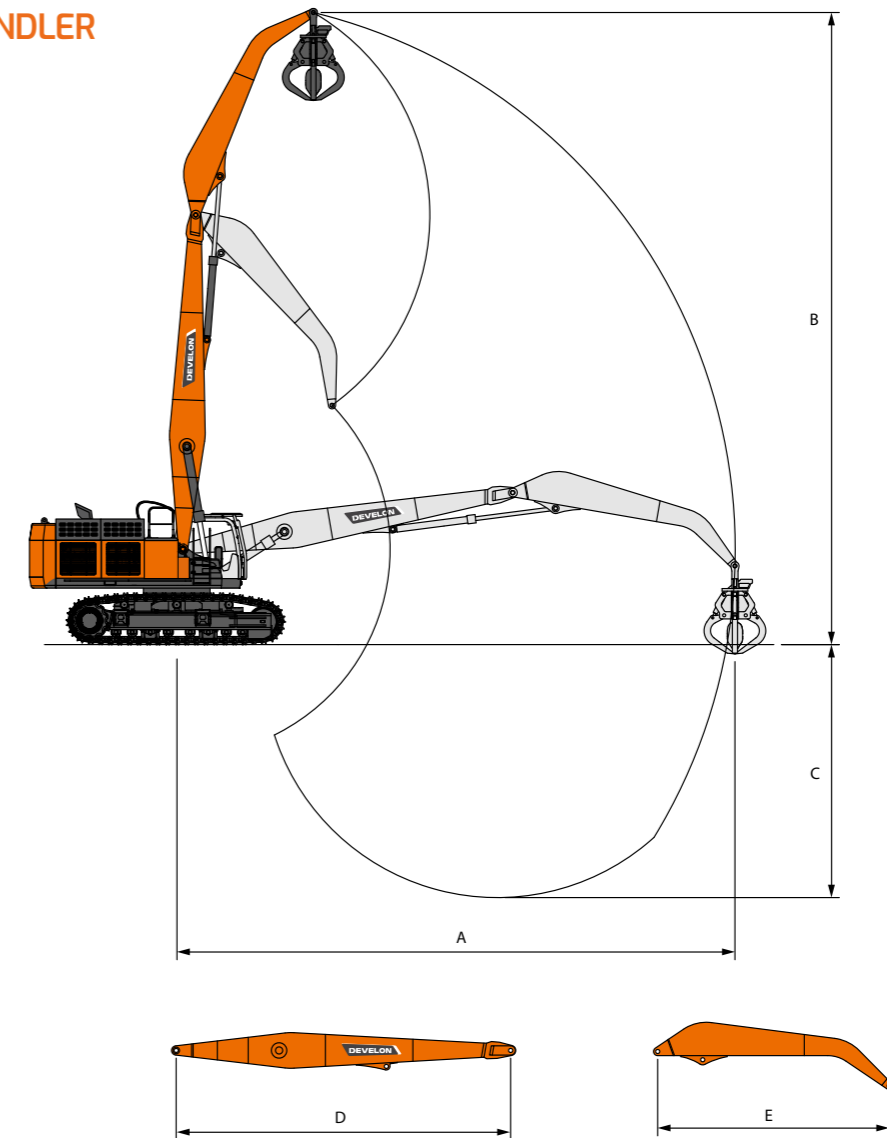

## WORKING RANGES

Max. Arm End Reach	(mm)	A	18,230
Max. Arm End Height	(mm)	B	19,680
Max. Arm End Depth	(mm)	C	8,160
Boom Length	(mm)	D	10,900
Arm Length	(mm)	E	8,000
Additional Counterweight	(kg)	-	5,000

## MATERIAL HANDLER ATTACHMENTS

Model		Orange Grapple
		OG50
Capacity	(m <sup>3</sup> )	0.97



**Orange Grapple** is commonly designed for handling scrap iron in wrecking yards or recycling plants and waste in landfill sites. Sometime it also used in building sites for transferring stones.

# SPECIAL APPLICATION

Develon provide various solution & various custom job application.

## HIGH REACH DEMOLITION

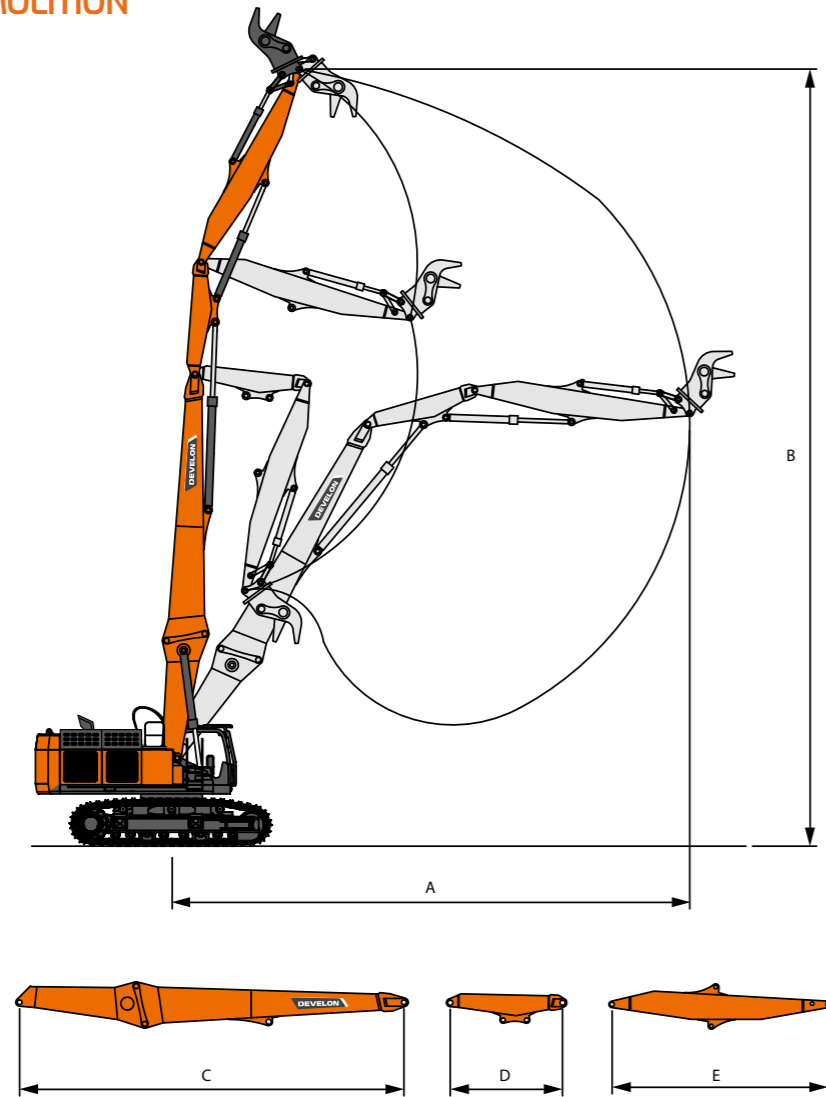

## WORKING RANGES

Max. Arm End Reach	(mm)	A	22,000
Max. Arm End Height	(mm)	B	36,010
Max. Arm End Depth	(mm)	C	18,400
Boom Length	(mm)	D	2,800
Arm Length	(mm)	E	12,200

## DEMOLITION ATTACHMENTS

Model	Rotating Crusher	Multi-Processor
	RC34	MP34
Crushing Force(ton)	78	101
Opening Width(mm)	1,056	983



### Rotating Crusher

is designed for both primary demolition work and secondary concrete reduction. Especially for secondary demolition, it is ideal for breaking out concrete from fixed structure, pulverizing concrete, materials for recycling, cutting reinforced rods and small separating different steel profile, and working with high reach boom.



### Multi-Processor

is designed for all demolition sites by inter-changing jaw sets mounted on a single base unit.

## FRONT SHOVEL

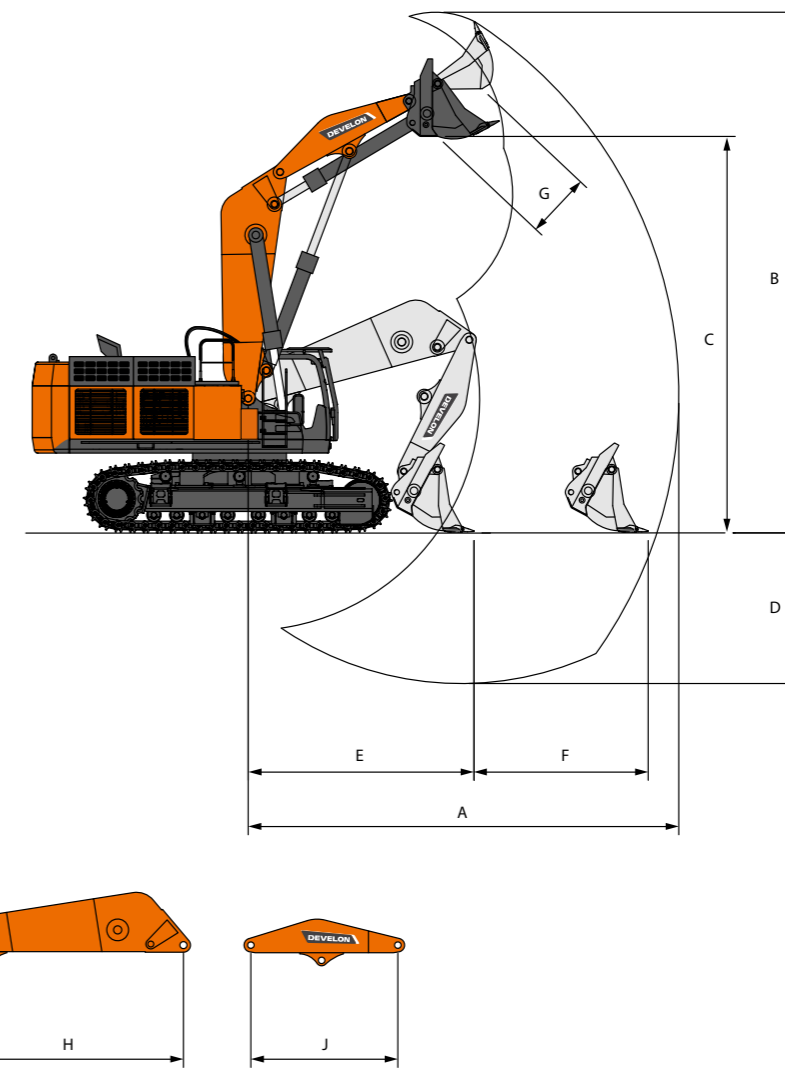

## WORKING RANGES

Max. Digging Reach	(mm)	A	10,550
Max. Digging Height	(mm)	B	12,180
Max. Dumping Height	(mm)	C	8,500
Max. Digging Depth	(mm)	D	4,900
Min. Digging Reach	(mm)	E	6,890
Digging Range On Ground	(mm)	F	3,660
Bucket Capacity(SAE/PCSA)	(m <sup>3</sup> )	G	5.5
Boom Length	(mm)	H	5,100
Arm Length	(mm)	J	3,200

## OPTIMIZED SHOVEL BUCKET

### Features & Benefits

- Spill guard is applied to load more capacity.
- High Grade material composition for better durability.
- Added more patches for durability and strength on lip plate and inner shell.
- Muscle pack heels to increase durability and protect shell from wear.

### Bottom Dump bucket

Green	HBN (Best Plate)
Red	HBN500
Purple	HBN400
Blue	CASTING

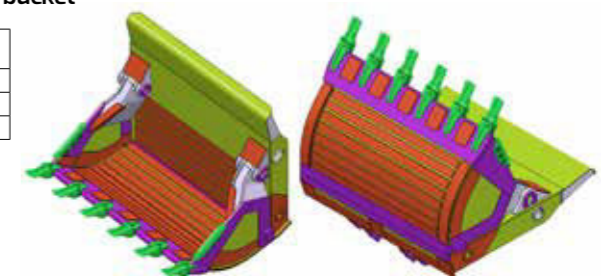

# TECHNICAL SPECIFICATION

## ENGINE

<b>Model</b>	Perkins 2806D (T3)
<b>Type</b>	Turbocharged after WATER-COOLED MEUI (Mechanically Actuated Electronically Controlled Unit Injector)
<b>Number of cylinders</b>	6
<b>RATED HORSE POWER</b>	470 kW (639 PS) @ 2,100rpm (ISO14396, Gross) (T3)
<b>Max torque</b>	282.4 kgf.m @ 1,400 rpm (T3)
<b>Piston displacement</b>	18.1 l
<b>Bore &amp; stroke</b>	Ø 145 mm x 183 mm
<b>Starting motor</b>	24 V x 9.0 kW
<b>Batteries</b>	24 V (12 V X 2 / 200 AH)
<b>Air cleaner</b>	Double element with precleaner

## HYDRAULIC SYSTEM

The heart of the system is the EPOS™ (Electronic Power Optimizing System). It allows the efficiency of the system to be optimized for all working conditions and minimizes fuel consumption. The new EPOS™ is connected to the engine electronic control via a data transfer link to harmonize the operation of the engine and hydraulics.

- The hydraulic system enables independent or combined operations.
- Two travel speeds offer either increased torque or high speed tracking.
- Cross-sensing pump system for fuel savings.
- Auto deceleration system.
- Two operating modes, two power modes.
- Button control of flow in auxiliary equipment circuits.
- Computer-aided pump power control.

### Main pumps

Tandem, Axial piston  
Max flow : 3 X 523 l/min @ 100 bar, 1,800 rpm  
Displacement : 280 X 3 cc/rev

### Pilot pump

Gear pump - max flow : 60 l/min  
Pilot pump : 32 cc/rev

### Main relief Pressure

Main Relief Valve Pressure : 360 bar (367 kgf/cm<sup>2</sup>)  
Travel Crossover Relief Valve Pressure : 368 bar (375 kgf/cm<sup>2</sup>)  
Swing Crossover Relief Valve Pressure : 294 bar (300 kgf/cm<sup>2</sup>)

## HYDRAULIC CYLINDERS

The piston rods and cylinder bodies are made of high-strength steel. A shock absorbing mechanism is fitted in all cylinders to ensure shock-free operation and extend piston life.

Cylinders	Quantity	Bore x Rod diameter x stroke
Boom	2	215 X 150 X 1,905 mm
Arm	1	240 X 170 X 2,020 mm
Bucket	1	210 X 145 X 1,530 mm

## UNDERCARRIAGE

Extremely robust construction throughout - made of high-quality, durable materials, with all welded structures designed to limit stresses.

- Track rollers lubricated for life
- Idlers and sprockets fitted with floating seals
- Track shoes made of induction-hardened alloy with double grouser
- Heat-treated connecting pins
- Hydraulic track adjuster with shock-absorbing tension mechanism

Upper rollers - 3

Lower rollers - 9

Track shoes - 51

Overall track length - 6,341 mm

## SWING MECHANISM

High-torque, axial piston motor with planetary reduction gear bathed in oil. Swing circle is singlerow, shear type ball bearing with induction-hardened internal gear. Internal gear and pinion gear immersed in lubricant.

**Max. Swing speed(Theoretical)** - 6.3 rpm

**Max. Swing Torque(Theoretical)** - 39,330 kgf.m (386 kN.m)

## DRIVE

Each track is driven by an independent, high-torque, axial piston motor through planetary reduction gear. Two levers or foot pedal control provide smooth travel or counter-rotation upon demand.

**Travel speed (High / low)** - 4.5 / 2.8 km/h

**Maximum traction force** - 78.7 / 47.9 ton.f

**Gradeability** - 70%

## REFILL CAPACITIES

**Fuel tank** - 1100 ℓ

**Cooling system** - 99.8 ℓ (T3)

**Engine oil** - 65 ℓ

**Swing device** - 2 X 8 ℓ

**Final device** - 2 X 25 ℓ

**Hydraulic tank** - 880 ℓ

## WEIGHT

Shoe Width	Ground Pressure	Operating Weight
STD. 650DG mm	1.37 kgf/cm <sup>2</sup>	97.9 ton
OPT. 750DG mm	1.19 kgf/cm <sup>2</sup>	98.5 ton
OPT. 750DG mm	1.20 kgf/cm <sup>2</sup>	98.8 ton
OPT. 900DG mm	1.01 kgf/cm <sup>2</sup>	100.2 ton

## BUCKET DIGGING FORCES

Bucket Type	Capacity (m <sup>3</sup> )	Width (mm)		Digging force (ton)
	SAE/PCSA	W / O Cutter	With Cutter	
S Class	5.4	1,940	1,940	STD/OPT [SAE] 40 / 44.8 [ISO] 42.96 / 48.2
	6.8	2,320	2,320	

Based on ISO 10567 and SAE J296, arm length without quick change clamp

## ARM DIGGING FORCES

Arm	Length	Weight	Digging force (ton)
Standard	3,750 mm	3,563 kg	[SAE] 36.22, [ISO] 36.73
Short	2,900 mm	3,283 kg	[SAE] 40.3, [ISO] 40.8

# DIMENSION

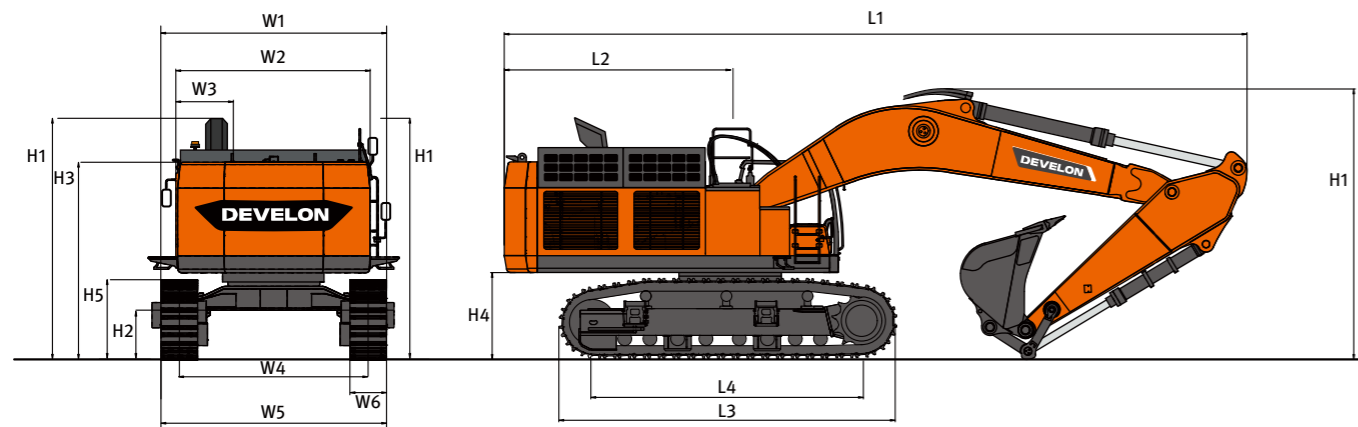

BOOM TYPE(ONE PIECE)		mm	7,250	8,400
ARM TYPE		mm	2,900	3,750
BUCKET TYPE		m <sup>3</sup>	6.8	5.4
Under Carriage(Grouser)			650DG	650DG
L1	Overall Length	mm	13,800	14,550
H1	Overall Height	Boom	mm	5,090
		Hose	mm	5,150
		Cabin	mm	3,615
		Hand/Guard Rail	mm	4,175
W1	Overall Width (Shipping)	mm	3,440	
	Rear Swing Radius	mm	4,620	
H2	Ground Clearance	mm	*860	
L2	Rear End Distance	mm	4,565	
W2	House Width	mm	***3,410/4,450	
W3	Cabin Width	mm	1,010	
H3	Height Over Cover (Bonet)	mm	3,785	
H4	Counterweight Clearance	mm	*1,560/1,615	
H5	Track Height	mm	*1,350/1,405	
L3	Track Length	mm	6,341	
L4	Tumbler Distance	mm	5,100	
W5	Undercarriage Width [without step]	mm	**3,440/4,200	
	Undercarriage Width [with step]	mm	**3,732/4,492	
W6	Shoe Width	mm	650	
	Grouser Height	mm	52	

\*: without Grouser / with Grouser  
 \*\*: Retracted / Extended  
 \*\*\*: without Catwalk / with Catwalk

# WORKING RANGE

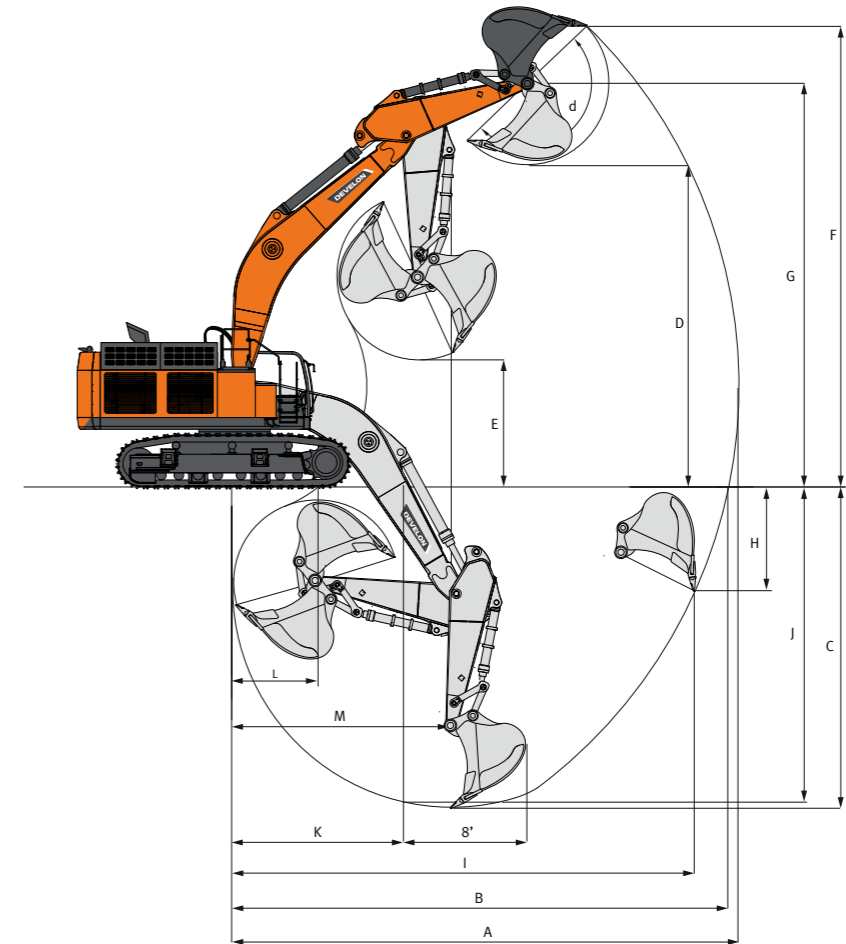

BOOM TYPE(ONE PIECE)		mm	7,250	8,400
ARM TYPE		mm	2,900	3,750
BUCKET TYPE		m <sup>3</sup>	6.8	5.4
A	MAX. DIGGING REACH	mm	12,430	14,275
B	MAX. DIGGING REACH (GROUND)	mm	12,110	14,000
C	MAX. DIGGING DEPTH	mm	7,260	8,795
D	MAX. LOADING HEIGHT	mm	8,100	9,440
E	MIN. LOADING HEIGHT	mm	3,910	4,210
F	MAX. DIGGING HEIGHT	mm	12,425	13,840
G	MAX. BUCKET PIN HEIGHT	mm	10,515	11,862
H	MAX. VERTICAL WALL DEPTH	mm	2,965	4,470
I	MAX. RADIUS VERTICAL	mm	10,995	12,265
J	MAX. DEPTH TO 8'LINE	mm	7,110	8,665
K	MIN. RADIUS 8' LINE	mm	4,410	5,290
L	MIN. DIGGING REACH	mm	1,970	3,365
M	MIN. SWING RADIUS	mm	5,345	6,295
d	BUCKET ANGLE	mm	145.3	143.8

# TRANSPORTATION

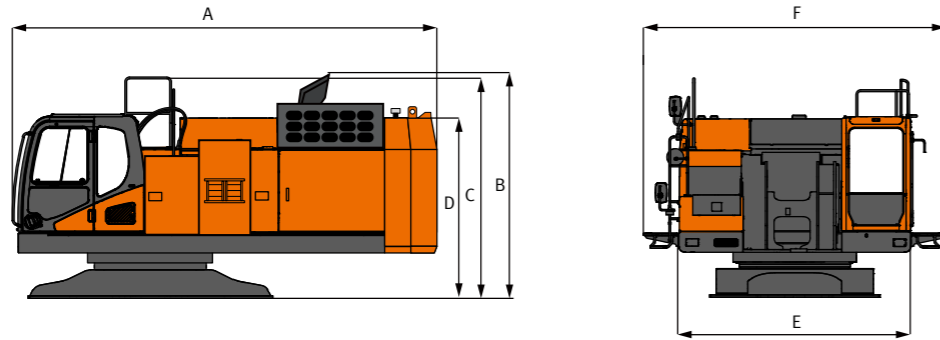

## UPPER STRUCTURE

Length	(mm)	A	6,282
Height (Top of Guardrail)	(mm)	B	3,280
Height (Top of Muffler)	(mm)	C	3,215
Height (Top of Cab)	(mm)	D	2,720
Width (Without Walkway)	(mm)	E	3,410
Width (With Walkway)	(mm)	F	4,450
Weight	(kg)	-	32,870

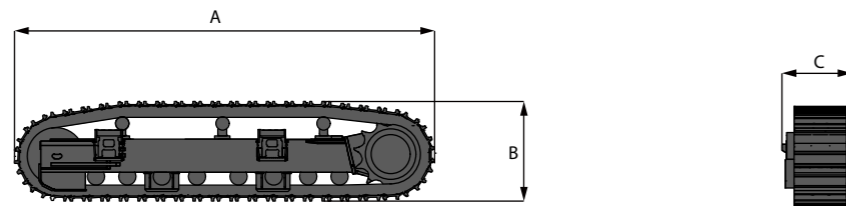

## UNDERCARRIAGE

Length	(mm)	A	6,341
Height	(mm)	B	1,452
Width (With Steps)	(mm)	C	1,186
Weight	(kg)	-	14,150

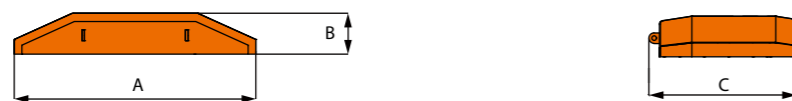

## COUNTERWEIGHT (STD)

Width	(mm)	A	4,450
Length	(mm)	B	730
Height	(mm)	C	2,119
Weight	(kg)	-	12,700



## COUNTERWEIGHT (Removal Opt.)

Width	(mm)	A	4,450
Length	(mm)	B	675
Height	(mm)	C	1,968
Weight	(kg)	-	11,300

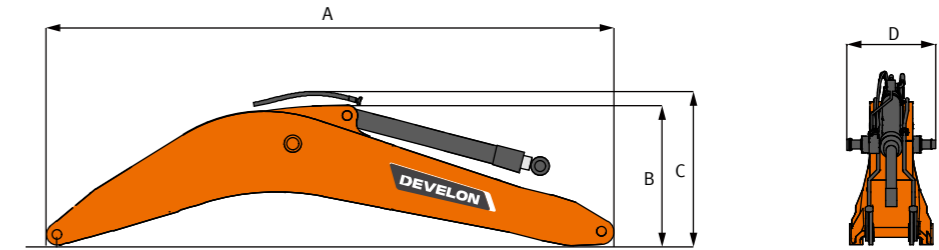

## BOOM

Length	(mm)	A	8,400	8.4m	7,250	7.25m
Height (Top of Boom)	(mm)	B	2,220	2,220	2,465	2,465
Height (Top of Hoses)	(mm)	C	2,340	2,340	2,610	2,610
Width	(mm)	D	1,340	1,340	1,340	1,340
Weight	(kg)	-	10,740	10,740	10,230	10,230

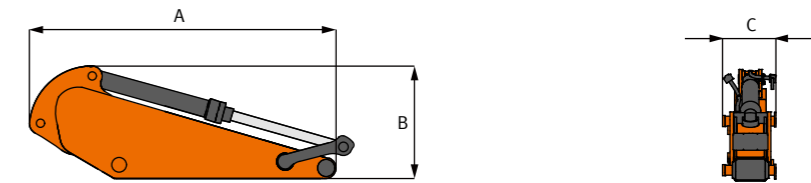

## ARM

Length	(mm)	A	5,305	3.7m	4,490	2.9m
Height	(mm)	B	1,730	1,730	1,500	1,500
Width	(mm)	C	820	820	820	820
Weight	(kg)	-	5,825	5,825	5,590	5,590

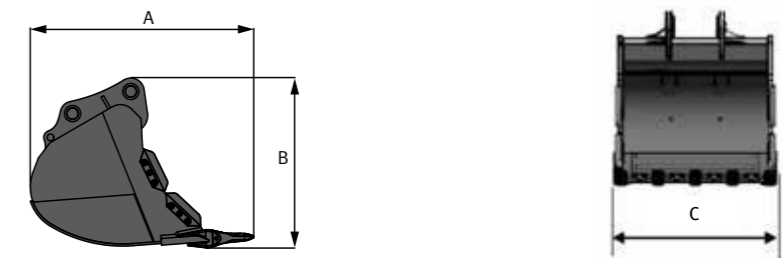

## BUCKET

Length	(mm)	A	2,750	5.4m <sup>3</sup>	2,750	6.8m <sup>3</sup>
Height	(mm)	B	2,350	2,350	2,350	2,350
Width	(mm)	C	1,940	1,940	1,940	2,320

# LIFTING CAPACITY

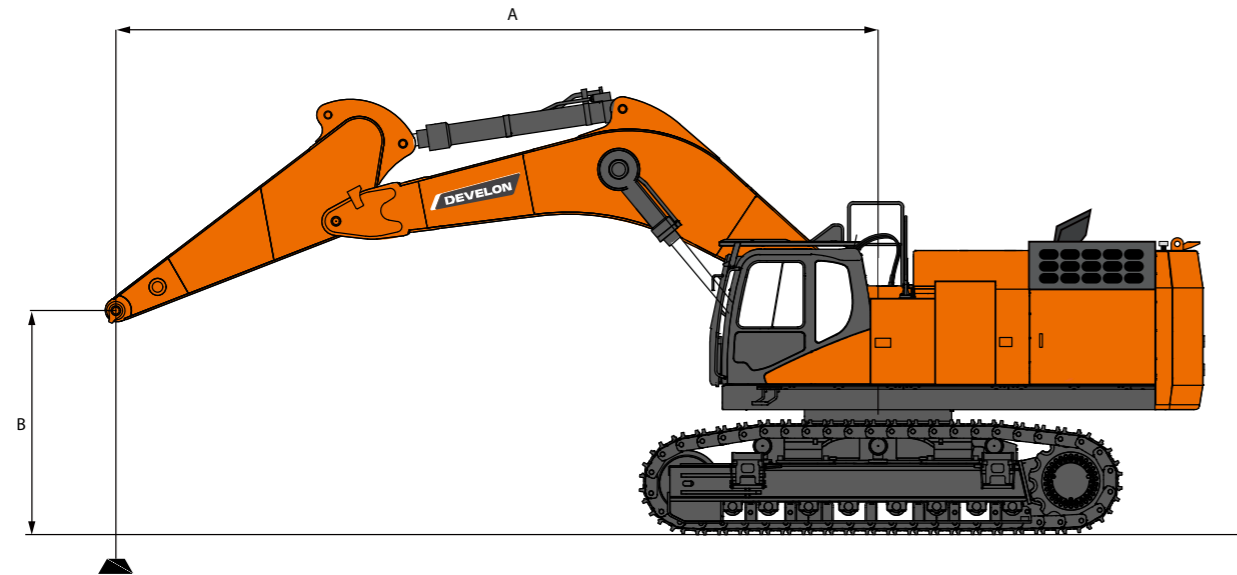

## STANDARD

### Metric

Boom: 7,250 mm (23'9") Arm: 2,900 mm (9'6") Shoe: 650 mm (2'1") Counterweight: 12,760 kg (28,126lb)

A(m) B(m)	4.5		6		7.5		9		Max		Reach (m)
10.5									19.98 *	19.98 *	Max. at(m) 6.40
9					21.16 *	21.16 *			17.95 *	17.95 *	Max. at(m) 7.90
7.5					21.36 *	21.36 *			17.12 *	17.12 *	Max. at(m) 8.91
6			26.69 *	26.69 *	22.77 *	22.77 *	20.63 *	19.84	16.94 *	16.94 *	Max. at(m) 9.57
4.5			30.62 *	30.62 *	24.73 *	24.73 *	21.48 *	19.26	17.25 *	16.35	Max. at(m) 9.96
3			34.06 *	33.81	26.63 *	24.38	22.42 *	18.64	18.06 *	15.64	Max. at(m) 10.10
1.5			35.83 *	32.51	27.90 *	23.51	23.05 *	18.13	19.47 *	15.55	Max. at(m) 10.02
0			35.76 *	31.96	28.14 *	23.02	22.94 *	17.83	20.80 *	16.12	Max. at(m) 9.70
-1.5	43.15 *	43.15 *	34.02 *	31.92	27.04 *	22.91	21.42 *	17.87	20.89 *	17.57	Max. at(m) 9.13
-3	37.87 *	37.87 *	30.36 *	30.36 *	23.91 *	23.25			20.57 *	20.57 *	Max. at(m) 8.23
-4.5	29.38 *	29.38 *	23.41 *	23.41 *					19.02 *	19.02 *	Max. at(m) 6.89

### Feet

A(ft) B(ft)	15		20		25		30		Max		Reach (ft)
35									44.04 *	44.04 *	Max. at(ft) 20.99
30					46.64 *	46.64 *			39.57 *	39.57 *	Max. at(ft) 25.93
25					47.08 *	47.08 *			37.73 *	37.73 *	Max. at(ft) 29.23
20			58.84 *	58.84 *	50.20 *	50.20 *	45.49 *	43.74	37.34 *	37.34 *	Max. at(ft) 31.39
15			67.52 *	67.52 *	54.52 *	54.52 *	47.36 *	42.46	38.04 *	36.05	Max. at(ft) 32.67
10			75.09 *	74.54	58.71 *	53.75	49.44 *	41.09	39.82 *	34.47	Max. at(ft) 33.15
5			78.99 *	71.68	61.50 *	51.83	50.81 *	39.96	42.92 *	34.27	Max. at(ft) 32.88
0			78.84 *	70.45	62.03 *	50.74	50.58 *	39.31	45.86 *	35.53	Max. at(ft) 31.84
-5	95.13 *	95.13 *	75.00 *	70.37	59.61 *	50.51	47.22 *	39.41	46.06 *	38.74	Max. at(ft) 29.94
-10	83.49 *	83.49 *	66.93 *	66.93 *	52.71 *	51.25			45.35 *	45.34	Max. at(ft) 27.00
-15	64.78 *	64.78 *	51.60 *	51.60 *					41.92 *	41.92 *	Max. at(ft) 22.61

- Load point is the end of the arm.
- Capacities marked with an asterisk (\*) are limited by hydraulic capacities.
- Lift capacities shown do not exceed 75 % of minimum tipping loads or 87 % of hydraulic capacities.
- The least stable position is over the side.
- Lift capacities apply only to the machine as originally manufactured and normally equipped by the manufacturer.
- The total mass of machine is 91,195 kg included in this mass boom 7.25 m, arm 2.9 m, 12,758 kg counterweight, 6.8 kg bucket, all operating fluids and a 75 kg operator.
- Lift capacities are in compliance with ISO 10567.

: Rating Over Front  
 : Rating Over Side or 360 Degree

## OPTION 1

### Metric

Boom: 7,250 mm (23'9") Arm: 2,900 mm (9'6") Shoe: 750 mm (2'4") Counterweight: 12,760 kg (28,126lb)

A(m) B(m)	4.5		6		7.5		9		Max		Reach (m)
10.5									19.98 *	19.98 *	Max. at(m) 6.40
9					21.16 *	21.16 *			17.95 *	17.95 *	Max. at(m) 7.90
7.5					21.36 *	21.36 *			17.12 *	17.12 *	Max. at(m) 8.91
6			26.69 *	26.69 *	22.77 *	22.77 *	20.63 *	19.96	16.94 *	16.94 *	Max. at(m) 9.57
4.5			30.62 *	30.62 *	24.73 *	24.73 *	21.48 *	19.39	17.25 *	16.46	Max. at(m) 9.96
3			34.06 *	34.03	26.63 *	24.54	22.42 *	18.76	18.06 *	15.74	Max. at(m) 10.10
1.5			35.83 *	32.73	27.90 *	23.67	23.05 *	18.25	19.47 *	15.65	Max. at(m) 10.02
0			35.76 *	32.17	28.14 *	23.17	22.94 *	17.96	20.80 *	16.23	Max. at(m) 9.70
-1.5	43.15 *	43.15 *	34.02 *	32.13	27.04 *	23.07	21.42 *	18	20.89 *	17.69	Max. at(m) 9.13
-3	37.87 *	37.87 *	30.36 *	30.36 *	23.91 *	23.4			20.57 *	20.57 *	Max. at(m) 8.23
-4.5	29.38 *	29.38 *	23.41 *	23.41 *					19.02 *	19.02 *	Max. at(m) 6.89

### Feet

A(ft) B(ft)	15		20		25		30		Max		Reach (ft)
35									44.04 *	44.04 *	Max. at(ft) 20.99
30					46.64 *	46.64 *			39.57 *	39.57 *	Max. at(ft) 25.93
25					47.08 *	47.08 *			37.73 *	37.73 *	Max. at(ft) 29.23
20			58.84 *	58.84 *	50.20 *	50.20 *	45.49 *	44.01	37.34 *	37.34 *	Max. at(ft) 31.39
15			67.52 *	67.52 *	54.52 *	54.52 *	47.36 *	42.74	38.04 *	36.29	Max. at(ft) 32.67
10			75.09 *	75.01	58.71 *	54.1	49.44 *	41.36	39.82 *	34.71	Max. at(ft) 33.15
5			78.99 *	72.15	61.50 *	52.18	50.81 *	40.23	42.92 *	34.51	Max. at(ft) 32.88
0			78.84 *	70.92	62.03 *	51.09	50.58 *	39.59	45.86 *	35.78	Max. at(ft) 31.84
-5	95.13 *	95.13 *	75.00 *	70.84	59.61 *	50.85	47.22 *	39.68	46.06 *	39.01	Max. at(ft) 29.94
-10	83.49 *	83.49 *	66.93 *	66.93 *	52.71 *	51.6			45.35 *	45.35 *	Max. at(ft) 27.00
-15	64.78 *	64.78 *	51.60 *	51.60 *					41.92 *	41.92 *	Max. at(ft) 22.61

- Load point is the end of the arm.
- Capacities marked with an asterisk (\*) are limited by hydraulic capacities.
- Lift capacities shown do not exceed 75 % of minimum tipping loads or 87 % of hydraulic capacities.
- The least stable position is over the side.
- Lift capacities apply only to the machine as originally manufactured and normally equipped by the manufacturer.
- The total mass of machine is 91,637 kg included in this mass boom 7.25 m, arm 2.9 m, 12,758 kg counterweight, 6.8 kg bucket, all operating fluids and a 75 kg operator.
- Lift capacities are in compliance with ISO 10567.

: Rating Over Front  
 : Rating Over Side or 360 Degree

# LIFTING CAPACITY

## OPTION 2

### Metric

Boom: 8,400 mm (27'6") Arm: 3,750 mm (12'1") Shoe: 750 mm (24") Counterweight: 12,760 kg (28,126lb)

A(m) B(m)	4.5		6		7.5		9		10.5		Max		Reach (m)
10.5							15.25 *	15.25 *			14.63 *	14.63 *	Max. at(m) 9.06
9							17.95 *	17.95 *			13.90 *	13.90 *	Max. at(m) 10.17
7.5					20.71 *	20.71 *	18.47 *	18.47 *	17.01 *	15.53	13.63 *	13.63 *	Max. at(m) 10.96
6					22.52 *	22.52 *	19.41 *	19.41 *	17.35 *	15.18	13.67 *	12.87	Max. at(m) 11.50
4.5					24.49 *	24.49 *	20.48 *	18.75	17.86 *	14.69	14.00 *	12	Max. at(m) 11.83
3					26.09 *	23.34	21.41 *	17.91	18.30 *	14.19	14.64 *	11.53	Max. at(m) 11.95
1.5					26.88 *	22.31	21.92 *	17.22	18.47 *	13.76	15.63 *	11.42	Max. at(m) 11.88
0					26.68 *	21.71	21.80 *	16.76	18.16 *	13.46	15.67 *	11.67	Max. at(m) 11.62
-1.5			31.29 *	30.12	25.46 *	21.48	20.88 *	16.55	17.09 *	13.36	15.37 *	12.36	Max. at(m) 11.14
-3	33.04 *	33.04 *	28.04 *	28.04 *	23.16 *	21.56	18.91 *	16.61			14.81 *	13.68	Max. at(m) 10.43
-4.5	27.13 *	27.13 *	23.42 *	23.42 *	19.41 *	19.41 *	15.18 *	15.18 *			13.70 *	13.70 *	Max. at(m) 9.41
-6			16.64 *	16.64 *	13.05 *	13.05 *					11.34 *	11.34 *	Max. at(m) 7.98

### Feet

A(ft) B(ft)	15		20		25		30		35		Max		Reach (ft)
35							33.63 *	33.63 *			32.26 *	32.26 *	Max. at(ft) 29.72
30							39.57 *	39.57 *			30.65 *	30.65 *	Max. at(ft) 33.37
25					45.66 *	45.66 *	40.71 *	40.71 *	37.49 *	34.25	30.04 *	30.04 *	Max. at(ft) 35.97
20					49.64 *	49.64 *	42.78 *	42.78 *	38.25 *	33.47	30.14 *	28.38	Max. at(ft) 37.74
15					53.99 *	53.99 *	45.16 *	41.33	39.37 *	32.39	30.87 *	26.45	Max. at(ft) 38.80
10					57.52 *	51.45	47.20 *	39.47	40.35 *	31.28	32.26 *	25.43	Max. at(ft) 39.21
5					59.26 *	49.19	48.32 *	37.96	40.72 *	30.33	34.47 *	25.18	Max. at(ft) 38.98
0					58.82 *	47.86	48.06 *	36.94	40.04 *	29.68	34.55 *	25.74	Max. at(ft) 38.11
-5			68.99 *	66.39	56.14 *	47.35	46.04 *	36.49	37.68 *	29.46	33.88 *	27.26	Max. at(ft) 36.55
-10	72.85 *	72.85 *	61.82 *	61.82 *	51.05 *	47.54	41.69 *	36.62			32.66 *	30.16	Max. at(ft) 34.20
-15	59.81 *	59.81 *	51.64 *	51.64 *	42.80 *	42.80 *	33.46 *	33.46 *			30.21 *	30.21 *	Max. at(ft) 30.86
-20			36.68 *	36.68 *	28.77 *	28.77 *					25.01 *	25.01 *	Max. at(ft) 26.19

1. Load point is the end of the arm.
2. Capacities marked with an asterisk (\*) are limited by hydraulic capacities.
3. Lift capacities shown do not exceed 75 % of minimum tipping loads or 87 % of hydraulic capacities.
4. The least stable position is over the side.
5. Lift capacities apply only to the machine as originally manufactured and normally equipped by the manufacturer.
6. The total mass of machine is 92,521 kg included in this mass boom 8.4 m, arm 3.7 m, 12,758 kg counterweight, 5.4 kg bucket, all operating fluids and a 75 kg operator.
7. Lift capacities are in compliance with ISO 10567.

: Rating Over Front  
 : Rating Over Side or 360 Degree

## OPTION 3

### Metric

Boom: 8,400 mm (27'6") Arm: 3,750 mm (12'1") Shoe: 900 mm (2'9") Counterweight: 12,760 kg (28,126lb)

A(m) B(m)	4.5		6		7.5		9		10.5		Max		Reach (m)
10.5							15.25 *	15.25 *			14.63 *	14.63 *	Max. at(m) 9.06
9							17.95 *	17.95 *			13.90 *	13.90 *	Max. at(m) 10.17
7.5							20.71 *	20.71 *	18.47 *	18.47 *	17.01 *	15.73	Max. at(m) 10.96
6							22.52 *	22.52 *	19.41 *	19.41 *	17.35 *	15.38	Max. at(m) 11.50
4.5							24.49 *	24.49 *	20.48 *	18.99	17.86 *	14.89	Max. at(m) 11.83
3							26.09 *	23.64	21.41 *	18.15	18.30 *	14.39	Max. at(m) 11.95
1.5							26.88 *	22.62	21.92 *	17.46	18.47 *	13.96	Max. at(m) 11.88
0							26.68 *	22.01	21.80 *	17	18.16 *	13.66	Max. at(m) 11.62
-1.5			31.29 *	30.53	25.46 *	21.78	20.88 *	16.79	17.09 *	13.56	15.37 *	12.55	Max. at(m) 11.14
-3	33.04 *	33.04 *	28.04 *	28.04 *	23.16 *	21.87	18.91 *	16.85			14.81 *	13.88	Max. at(m) 10.43
-4.5	27.13 *	27.13 *	23.42 *	23.42 *	19.41 *	19.41 *	15.18 *	15.18 *			13.70 *	13.70 *	Max. at(m) 9.41
-6			16.64 *	16.64 *	13.05 *	13.05 *					11.34 *	11.34 *	Max. at(m) 7.98

### Feet

A(ft) B(ft)	15		20		25		30		35		Max		Reach (ft)
35							33.63 *	33.63 *			32.26 *	32.26 *	Max. at(ft) 29.72
30							39.57 *	39.57 *			30.65 *	30.65 *	Max. at(ft) 33.37
25							45.66 *	45.66 *	40.71 *	40.71 *	37.49 *	34.69	Max. at(ft) 35.97
20							49.64 *	49.64 *	42.78 *	42.78 *	38.25 *	33.91	Max. at(ft) 37.74
15							53.99 *	53.99 *	45.16 *	41.86	39.37 *	32.83	Max. at(ft) 38.80
10							57.52 *	52.12	47.20 *	40.01	40.35 *	31.72	Max. at(ft) 39.21
5							59.26 *	49.86	48.32 *	38.49	40.72 *	30.77	Max. at(ft) 38.98
0							58.82 *	48.53	48.06 *	37.48	40.04 *	30.12	Max. at(ft) 38.11
-5			68.99 *	67.31	56.14 *	48.02	46.04 *	37.02	37.68 *	29.9	33.88 *	27.66	Max. at(ft) 36.55
-10	72.85 *	72.85 *	61.82 *	61.82 *	51.05 *	48.21	41.69 *	37.16			32.66 *	30.6	Max. at(ft) 34.20
-15	59.81 *	59.81 *	51.64 *	51.64 *	42.80 *	42.80 *	33.46 *	33.46 *			30.21 *	30.21 *	Max. at(ft) 30.86
-20			36.68 *	36.68 *	28.77 *	28.77 *					25.01 *	25.01 *	Max. at(ft) 26.19

1. Load point is the end of the arm.
2. Capacities marked with an asterisk (\*) are limited by hydraulic capacities.
3. Lift capacities shown do not exceed 75 % of minimum tipping loads or 87 % of hydraulic capacities.
4. The least stable position is over the side.
5. Lift capacities apply only to the machine as originally manufactured and normally equipped by the manufacturer.
6. The total mass of machine is 93,714 kg included in this mass boom 8.4 m, arm 3.7 m, 12,758 kg counterweight, 5.4 kg bucket, all operating fluids and a 75 kg operator.
7. Lift capacities are in compliance with ISO 10567.

: Rating Over Front  
 : Rating Over Side or 360 Degree

# STANDARD & OPTION

## STANDARD EQUIPMENT

### Boom

- 7.25 m Boom

### Arm

- 2.9 m Arm

### Hydraulic system

- Boom and arm flow regeneration
- Boom and arm holding valves
- Swing anti-rebound valves
- Spare ports (Control valve)

### Cabin & Interior

- Viscous cab mounts
- All weather sound suppressed type cab
- Air conditioner & Heater
- Adjustable suspension seat with head rest and adjustable arm rest
- Pull-up type front window and removable lower front window
- Room light
- Intermittent windshield wiper
- Cigarette lighter and ashtray
- Cup holder
- Hot & Cool box
- LCD color monitor panel
- E/G RPM control dial
- AM/FM radio + MP3 (USB)
- Remote radio ON/OFF switch
- 12V spare powers socket
- Serial communication port for laptop PC interface
- Joystick lever with 3 switches
- Sun visor
- Sun roof

### Safety

- Large handrails and step
- Convex metal anti-slip plates
- Seat belt
- Hydraulic safety lock lever
- Safety glass
- Hammer for emergency escape
- Right and left rearview mirrors
- Battery protector cover

### Others

- Double element air cleaner with two stage filtration
- Water separator
- Fuel filter
- Dust screen for radiator/oil cooler
- Engine overheat prevention system
- Engine restart prevention system
- Self-diagnostic system
- Alternator (24 V, 115 A)
- Electric horn
- LED working lights (boom mounted 2, frame mounted 2, storage box mounted 1)
- Hydraulic track adjuster
- Track guards
- Greased and sealed track link
- Hydraulic oil tank air breather filter

## OPTIONAL EQUIPMENT

Some of optional equipments may be standard in some markets. Some of this optional equipment is not available in some markets. You must check with the local DEVELON dealer to know about the availability or to release the adaptation following the needs of the applications

### Boom

- 8.4 m Boom

### Arm

- 3.75 m Arm

### Bucket (SAE/PSCA)

- 5.4 m<sup>3</sup> S Class Bucket
- 6.8 m<sup>3</sup> S Class Bucket
- Only Dummy Link No Bucket

### Boom Cylinder Guard

- Boom Cylinder Guard

### Bucket Cylinder Guard

- Bucket Cylinder Guard

### Track Shoe

- 650 mm Double Grouser Shoe
- 750 mm Double Grouser Shoe
- 900 mm Double Grouser Shoe

### Breaker Filter

- Breaker Filter

### Hydraulic Oil

- Cold Weather (VG32)
- Normal Weather (VG46)
- Tropical Weather (VG68)

### FOGS Guard

- FOGS
- Top Guard

### Mirror

- Side Mirror

### Lever Pattern Change

- Lever Pattern Change

### Rotating Piping(PERO)

- Rotating Piping(PERO)

### One & Two Way Piping

- Two Way with Pedal
- Two Way without Pedal
- One Way with Electric Pedal
- One Way

### Quick Coupler Piping

- Quick Coupler Piping

### Straight Travel

- Straight Travel

### Two Pumps & Piping

- Two Pumps

### Audio Equipment

- DAB Audio (Handsfree & Bluetooth)

### Rain Shield

- Rain Shield

### Alarm

- Alarm for All

### Camera

- Around View Camera
- Rear View Camera

### Cabin Front Guard

- Upper and Lower Guard
- Lower Guard Only

### Under Cover

- Standard Under Cover

### Additional Work Lamp

- 2 Additional Working Lamp(LED)
- 6 Additional Working Lamp(LED)

### Overload Warning Device

- Overload Warning Device

### Rotating Beacon

- Rotating Beacon

### Cabin Roof Cover

- Plastic Roof Cover
- Steel Roof Cover

### Additional Water Separator

- Additional Water Separator

### Telematics

- DEVELON Fleet Management

### Air Compressor

- Air Compressor

### Auto Greasing Unit

- Auto Greasing Unit

### Additional Mirror

- Additional Mirror

### Fuel Filler Pump

- Fuel Filler Pump

### Track Guard

- Full Track Guard

### Rear Sun Visor

- Rear Sun Visor

### Heating & Cooling Seat

- Heating & Cooling Seat

### Life Cycle Hydraulic Oil

- 4,000 Hour Cycle Hydraulic Oil
- 8,000 Hour Cycle Hydraulic Oil