

> We are DEVELON

We trace our roots to 1937 as one of Korea's first large scale machine plant. Throughout time we have consistently delivered exceptional products and solutions.

DEVELON is a bold name that reflects our core ambition to continue developing onwards and leaving behind a positive footprint in our world. Moving forward, we seek to be part of our customers and partners' endeavor to build a better world.

Powered by **Innovation**



©2023 HD Hyundai Infracore. All rights reserved.
HDIPBE-01-2306

Certain specification(s) are based on engineering calculations and are not actual measurements. Specification(s) are provided for comparison purposes only and are subject to change without notice. Specification(s) for your individual Develon equipment will vary based on normal variations in design, manufacturing, operating conditions, and other factors. Pictures of Develon units may show other than standard equipment

DEVELON

SD Wheel Loaders

SD200N
SD300N



develon-ce.com

SD200N

WILLING, CAPABLE AND LOADED



NEW STYLE

- Applied new look with newly added LED lamp and Develon decal, SD200N shows intense presence.

OVERALL CAPABILITY

- Matching between transmission and torque converter ensures maximum engine power.
- The fixed wheel transmission boasts stable performance, high reliability, a low failure rate and conveniently agile operation.

PROVEN SOLIDITY

- SD200N's advanced radiators enable lowering the hydraulic oil heat when equipment is in operation.
- All quick-wearing parts are equipped with wear-resistant sheaths. Develon provides a good warranty policy and offer a one stop service.

SAFETY PRIORITY

- Develon places great emphasis on your safety. A combination of our safe cabin design, top-grade rubber shock absorbers, specialized cushion pads, and drive system with a patented anti-vibration technology ensures operator safety.

SD200N STRENGTHENED CAPABILITY

START MOTOR

The newly-changed start-up mode of the motor and the enlarged CCA (Cold Cranking Amperes) capacity make it easy to start the motor in low-temperature environments.

ACCELERATION PERFORMANCE

The injection pump has undergone special debugging at a professional test bench and features greatly improved engine acceleration performance and speed.

PERFECTLY MATCHED POWER TRAIN

Engine, transmission and axles are optimized and finely tuned for each other and produce powerful traction force.



ENGINE (WP6G125E22)

The perfect blend of efficiency and power. The Weichai engine produces 92 KW at 2,200 rpm. High power and appropriate torque range enables to precisely deliver the stable working speed. Engine has undergone specific adjustments under different working conditions, consuming less fuel, accelerating faster and delivering more power.

PROVEN TO LAST

TRANSMISSION SHAFT

Double bearing supports propeller shaft in dual configuration. Lubricating oil can be infused easily, enhancing the durability.

REINFORCED PIN BUSHING

To work best in the most severe work environment, diameter of 6 pins is thicker than competitors by 5 ~ 10 mm.

RELIABLE HYDRAULIC COMPONENTS (MCV)

New solid main control valve has high precision machining which lowers inside leakage and prolongs the service life.

DURABLE AXLE DESIGN

More durable materials and technology are applied to machining gears.

BUCKET STRENGTH

SD200N has improved bucket strength with use of high anti-abrasion materials and increased thickness.

DURABILITY TEST

All vital components must pass extensive and stringent standard durability test.

WEAR-RESISTANT SHEATH

All easily worn-out parts are equipped with wear-resistant sheaths. Develon provides a good warranty policy and offer a one stop service

COOLING SYSTEM

By improving the layout and materials of the heat-dissipation system, to aluminum plate fin-type.

SD200N SIMPLIFIED MAINTENANCE

EASY APPROACH

Maintenance windows have been added to each side of the engine hood. Making daily oil inspection and maintenance works quicker and more convenient.

TRIPLE FUEL FILTER

Triple fuel filters protect engine and fuel system from low quality fuel and make engine life longer. Highest efficiency filters remove water, dust & particles to protect your investment optimally.

COOLING SYSTEM

Cooling system is readily accessible for clean out and maintenance routine.

AIR CLEANER FOR DUSTY ENVIRONMENT

Special air cleaner for extremely dusty environment is applied to prevent dust in the desert area from permeating into the engine.

EASILY CHANGEABLE BREAK DISCS

The use of quick-change brake discs allows the user to check brake pads for excessive wear at any time and change the brake pads more easily without removing the tires.



SD200N

COMFORT ON-BOARD

CABIN COMFORT

Ample space, wide visual field and intuitive features will guarantee a pleasant work. Cabin also reduces the noise and vibration significantly.

LED LAMP

Existing two front lamps and two rear lamps have been upgraded with LED. New additional working lamp contributes to enhanced safety through improved visibility.

ADJUSTABLE STEERING WHEEL

The adjustable steering wheel complies with ergonomic principles.

NEW OPERATOR PANEL

The new instrument gauge panel has been changed simple and intuitively to put essential information right in front of the operator.

ERGONOMICALLY DESIGNED PEDALS

The ergonomically designed pedals reduce fatigue and to lessen the load operator.

JOYSTICK LEVER

Highly intuitive joystick lever enables easier and safer operations.

DELUXE SEAT

High back, deep-seated position, dual armrests and multi-level spring shock absorption guarantee a comfortable operation.

ROTATING BEACON (OPTIONAL)

For enhanced safety rotating beacon is equipped SD200N as optional, which gives the warning alarm while driving

ALL AROUND VISIBILITY

Improved visibility to the Left and right bottom section of the front windshield for easy positioning of front wheels.

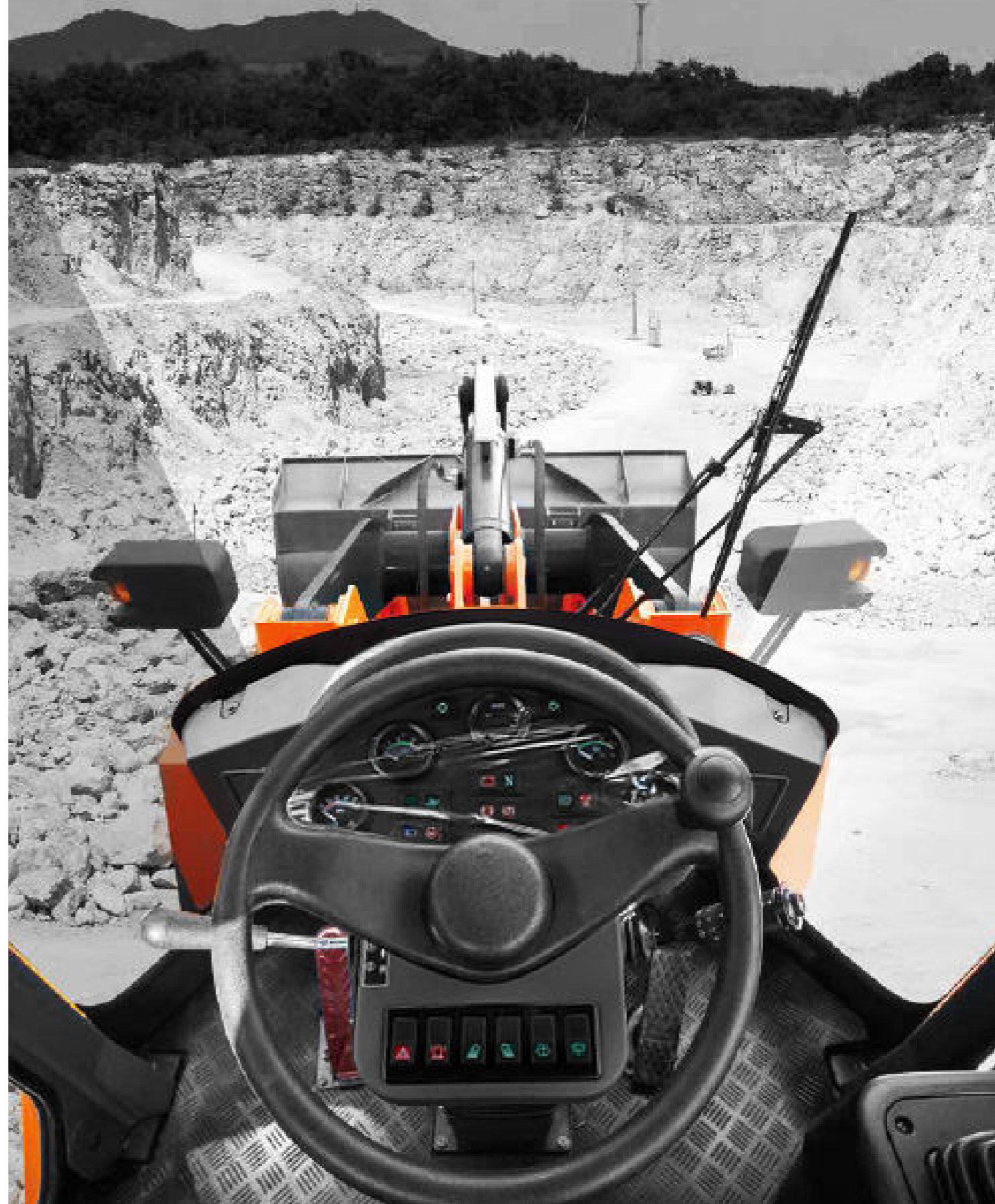

SD300N

AGILE, ADAPTIVE AND ASSURED

FEARLESS STYLE

- Applied new look with distinctive design and reinforced structure. With newly added LED lamp and Develon decal, SD300N shows intense presence and bold and assertive style.

PERFECTLY ORCHESTRATED WORKING FORCE

- SD300N's hydraulic system minimizes engine oil pressure load and power loss and enabling miniaturization of the hydraulic pump.

TIRELESS PARTNER IN TIMELESS QUALITY

- By using Develon patented technology and a redesigned layout and materials, the cooling system significantly reduces hydraulic oil temperature and water temperature during operation.
- The hydraulic cylinder seals and hydraulic holes in important areas are all verified brand parts, effectively improving the reliability of the hydraulic system.



SD300N A NEW LEAP ON EFFICIENCY

GEAR BOX

The torque converter gearbox perfectly matches the engine, gearshift-shock-improving technology efficiently prolongs the service life of it.

ACCELERATION PERFORMANCE

The injection pump has undergone special debugging at a professional test bench and features greatly improved engine acceleration performance and speed.

PERFECTLY MATCHED POWER TRAIN

Engine, transmission and axles are optimized and finely tuned for each other and produce powerful traction force.



ENGINE (WD10G220E23)

The perfect match of efficiency and power. The Weichai engine produces 162 kW at 2,000 rpm. High power and appropriate torque range enables to precisely deliver the stable working speed. Engine has undergone specific adjustments under different working conditions, consuming less fuel, accelerating faster, and delivering more power.

SD300N SIMPLIFIED MAINTENANCE

EASY APPROACH

Both sides of the hood can be opened to the side. Making daily oil inspection and maintenance works quicker and more convenient.

TRIPLE FUEL FILTER

Triple fuel filters protect engine and fuel system from low quality fuel and make engine life longer. Highest efficiency filters remove water, dust & particles to protect your investment optimally.

AIR CLEANER FOR DUSTY ENVIRONMENT

Special air cleaner for extremely dusty environment is applied to prevent dust in the desert area from permeating into the engine.

COOLING SYSTEM

Cooling system is readily accessible for clean out and maintenance routine.

EASILY CHANGEABLE BREAK DISCS

The use of quick-change brake discs allows the user to check brake pads for excessive wear at any time and change the brake pads more easily without removing the tires.

BOOSTER PUMP ACCESS

As being mounted on the body's side, the booster pump delivers a higher augmented-thrust ratio, more stable braking performance and more convenient daily maintenance.



BUILT TO STAND THROUGH

REINFORCED PIN BUSHING

To work best in the most severe work environment, diameter of 6 pins is thicker than competitors by 5 ~ 10 mm.

TRANSMISSION SHAFT

Double bearing supports propeller shaft in dual configuration. Lubricating oil can be infused easily, enhancing the durability.

STRUCTURE PART

SD300N is made of high-strength steel and calculated by finite element analysis software. The box-shaped structure of the rear frame side plates and enhanced frame strength makes it easy to meet the challenge posed by harsh working conditions.

DURABLE AXLE DESIGN

More durable materials and technology are applied to machining gears.

DURABILITY TEST

All vital components must pass extensive and stringent standard durability test.

JOINT BEARING

The method of articulating the front and rear frames has been replaced to joint bearings, effectively preventing loose and breakage.

SD300N OPERATOR COMFORT

CABIN COMFORT

Ample space, wide visual field and intuitive features will guarantee a pleasant work. Cabin also reduces the noise and vibration significantly.

LED LAMP

Existing front lamp has been upgraded to LED and totally six more lights have been added. Four additional LED lights on the front and two more on the back. New additional working lamp contributes to enhanced safety through improved visibility.

ADJUSTABLE STEERING WHEEL

The adjustable steering wheel complies with ergonomic principles

JOYSTICK LEVER

Highly intuitive joystick lever enables easier and safer operations.

SHOCK PAD

A new model of shock pad is used to provide stronger durability and reduced shock and noise, effectively relieving the operator's fatigue.

NEW OPERATOR PANEL

The new instrument gauge panel has been changed simple and intuitively to put essential information right in front of the operator.

ERGONOMICALLY DESIGNED PEDALS

The ergonomically designed pedals reduces fatigue and to lessen the load operator.

DELUXE SEAT

High back, deep-seated position, dual armrests and multi-level spring shock absorption guarantee a comfortable operation.

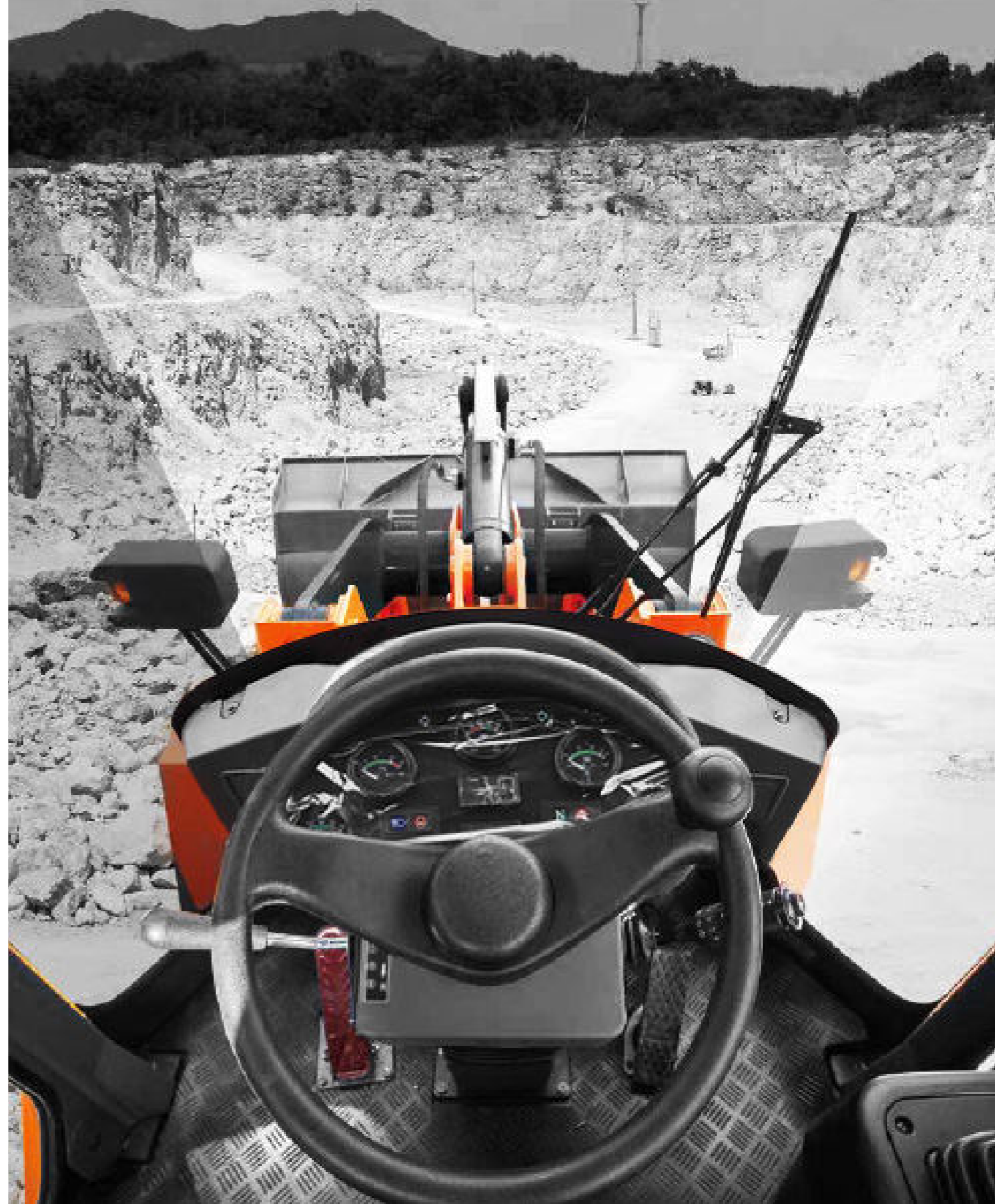

TECHNICAL SPECIFICATION (SD200N)

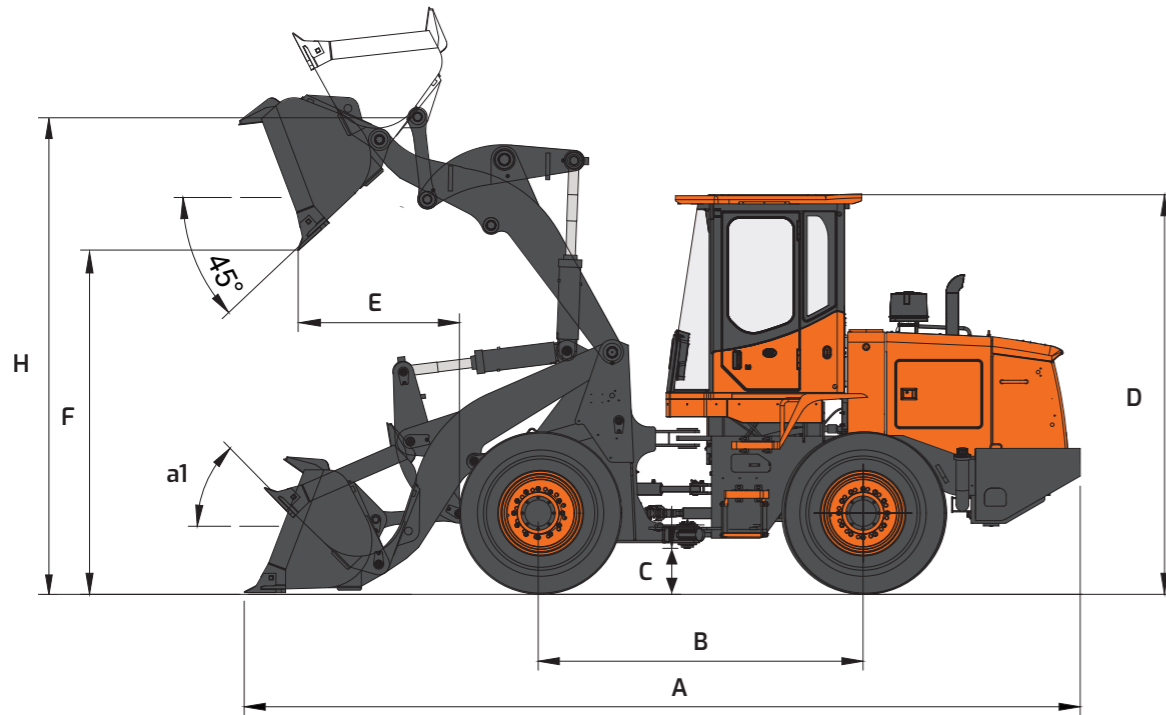

ENGINE

Model	Weichai WP6G125E22 (Tier 2)
Rated Power (SAE J1995 Gross)	92 kW (125 PS) @ 2,200 rpm
Max. Torque (SAE J1995 Gross)	500 N.m @ 1,400~1,500 rpm
Number of cylinders/bores/strokes	6 / 105 mm / 130 mm
Displacement	6.7 L
Fuel Consumption	215 g/kW.h @ RATED SPEED

TRANSMISSION

Type	4 speeds, power-shift, countershaft, engine remote mounted with propeller shaft & damper
Torque Converter Stall Ratio/Size	3.0 / 315 mm

HYDRAULIC SYSTEM

Main Pump Type	Fixed gear
Main Pump Displacement	100 cc/rev
Max. Flow Rate	215 l/min

GENERAL SPECIFICATIONS

Operating Weight	10.3 ton
Bucket Capacity (SAE HEAPED)	1.7 m ³
Payload	3,000 kg
Travel Speed (1/2/3/4)	8.5 / 13.0 / 24.0 / 37.0 km/h
Static Tipping Load (straight)	7,100 kg
System Pressure (Work/Steer)	170 / 140 kg/cm ²
Sound Level in CAB (2000/14/EC)	84 dB (A)
External Sound Power Level (2000/14/EC)	112 dB (A)
Fuel Tank Capacity	155 L
Tire Size	17.5 - 25 - 12 PR

DIMENSIONS & WORKING RANGE (SD200N)

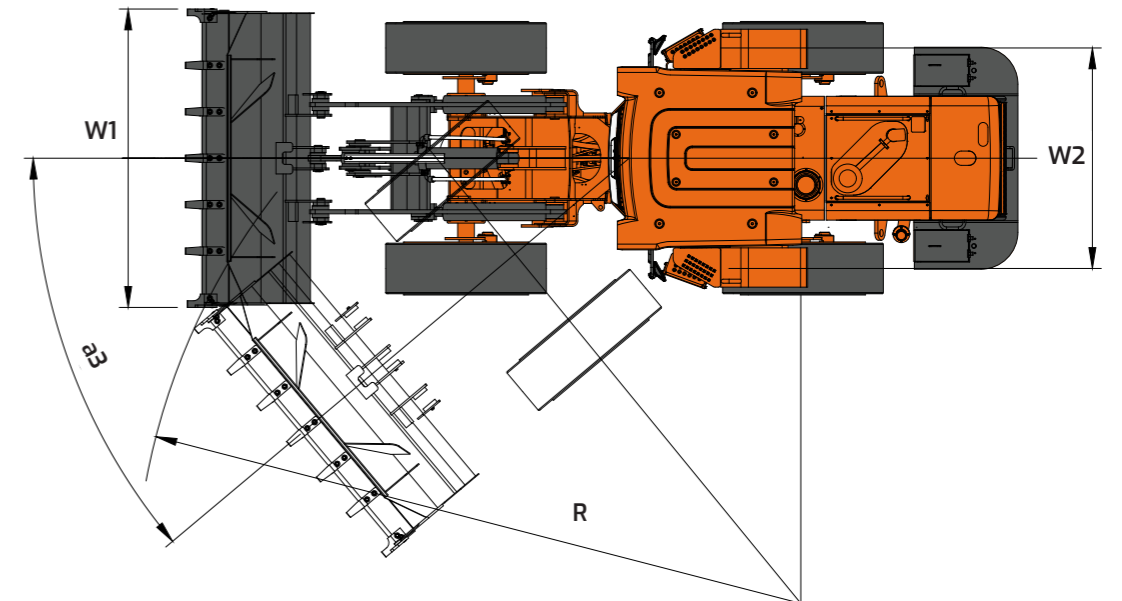

ITEMS		UNIT	STD.	OPT 1	OPT 2	OPT 3	
Operating Weight		ton	10.3	10.37	10.42	10.44	
Bucket Capacity (SAE HEAPED)		m ³	1.7	1.7	2.2	2.2	
Arm			STD.	LONG	STD.	LONG	
Breakout Force		kN	99	100.9	83.3	84.28	
Dimensions	Overall Length	A	mm	6,990	7,150	7,010	7,170
	Overall Width	W1	mm	2,496	2,496	2,506	2,506
	Overall Height	D	mm	3,250	3,250	3,250	3,250
	Ground Clearance	C	mm	330	330	330	330
	Wheel Base	B	mm	2,700	2,700	2,700	2,700
	Tread	W2	mm	1,850	1,850	1,850	1,850
	Working Range	Dump Height at 45° (with tooth)	F	mm	2,840	3,100	2,848
Dump Reach at 45° (with tooth)		E	mm	1,240	1,134	1,270	1,160
Max. Tilt Angle (on ground)		a1	degree (°)	45	45	45	45
Max. Tilt Angle (fully raised)			degree (°)	60	60	60	60
Max. Tilt Angle (at carry)			degree (°)	50	50	50	50
Height at bucket pivot point		H	mm	3,770	4,040	3,770	4,040
Digging Depth (0° level)			degree (°)	45	55	50	60
Max. Steering Angle		a3	degree (°)	38	38	38	38
Turning Radius (tire center)			mm	5,050	5,050	5,050	5,050
External radius at bucket edge		R	mm	5,540			
Gradeability		% (°)	58 (30)				

TECHNICAL SPECIFICATION (SD300N)

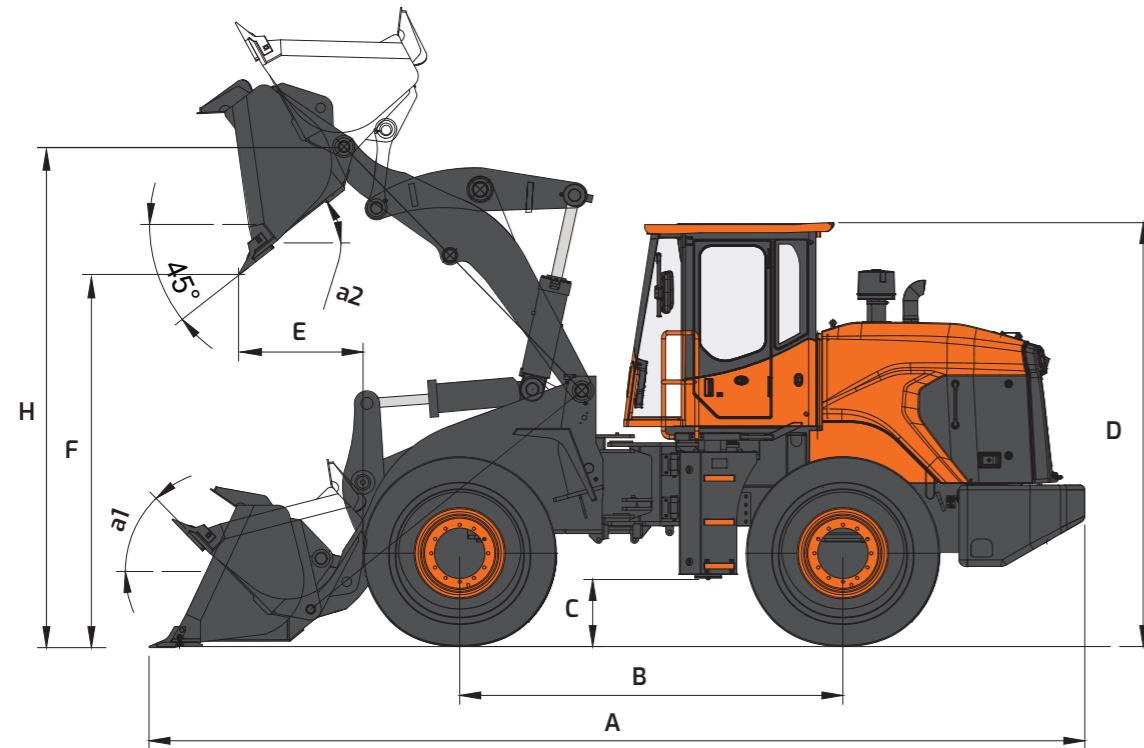

ENGINE

Model	Weichai WD10G220E23 (Tier 2)
Rated Power (SAE J1995 Gross)	162 kW (220 ps) @ 2,000 rpm
Max. Torque (SAE J1995 Gross)	980 N.m @ 1,300-1,500 rpm
Number of cylinders/bores/strokes	6 / 126 mm / 130 mm
Displacement	9.7 L
Fuel Consumption	≤215g/kW.h

TRANSMISSION

Type	Single-style, two-phase, Four element, dual turbine
Torque Converter Stall Ratio/Size	4.1 / 315 mm

HYDRAULIC SYSTEM

Main Pump Type	Fixed gear
Main Pump Displacement	100 cc/rev
Max. Flow Rate	215 l/min

GENERAL SPECIFICATIONS

Operating Weight	16.5 ton
Bucket Capacity (SAE HEAPED)	2.7 m ³
Payload	5,000 kg
Travel Speed (low/high)	12.2 / 38 km/h
Static Tipping Load (straight)	10,600 kg
System Pressure (Work/Steer)	170 / 160 kg/cm ²
Sound Level in CAB (2000/14/EC)	84.6 dB (A)
External Sound Power Level (2000/14/EC)	112 dB (A)
Fuel Tank Capacity	260 Litre
Tire Size	23.5 - 25 - 16 PR

DIMENSIONS & WORKING RANGE (SD300N)

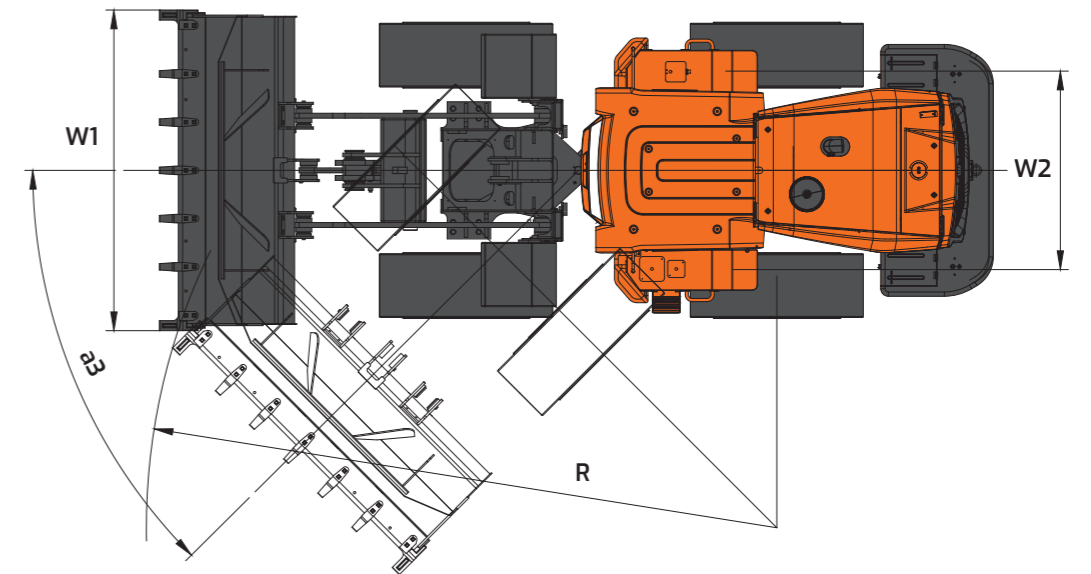

ITEMS		UNIT	STD.	OPT 1	OPT 2	OPT 3	OPT 4	OPT 5	OPT 6	OPT 7	
Operating Weight		ton	16.5	16.6	16.55	16.60	16.77	16.64	16.74	16.75	
Bucket Capacity (SAE HEAPED)		m ³	2.7	2.7	3.0	3.2	3.2	2.9	2.9	4.0	
Arm			STD.	LONG	STD.	STD.	LONG	STD.	LONG	STD.	
Breakout Force		kN	164	152	164	164	152	164	152	131	
Dimensions	Overall Length	A	mm	7,780	8,024	7,780	7,684	7,928	7,680	7,924	7,810
	Overall Width	W1	mm	2,992	2,992	2,992	2,944	2,944	2,944	2,944	3,092
	Overall Height	D	mm	3,470	3,470	3,470	3,470	3,470	3,470	3,470	3,470
	Ground Clearance	C	mm	480	480	480	480	480	480	480	480
	Wheel Base	B	mm	2,900	2,900	2,900	2,900	2,900	2,900	2,900	2,900
	Tread	W2	mm	2,174	2,174	2,174	2,174	2,174	2,174	2,174	2,174
	Dump Height at 45° (with tooth)	F	mm	3,027	3,309	3,027	3,116	3,390	3,116	3,390	2,960
Dump Reach at 45° (with tooth)	E	mm	1,338	1,325	1,330	1,275	1,264	1,275	1,264	1,310	
Working Range	Max. Dump Angle (fully raised)	a2	°	48	48	48	48	48	48	48	48
	Max. Tilt Angle (on ground)	a1	°	45	45	45	45	45	45	45	45
	Max. Tilt Angle (fully raised)		°	60	60	60	60	60	60	60	60
	Max. Tilt Angle (at carry)		°	50	50	50	50	50	50	50	50
	Height at bucket pivot point	H	mm	4,100	4,375	4,100	4,100	4,375	4,100	4,375	4,100
	Digging Depth (0° Level)		°	94	94	94	96	96	96	96	94
	Max. Steering Angle	a3	°	36	36	36	36	36	36	36	36
	Turning Radius (tire center)		mm	6,015	6,015	6,015	6,015	6,015	6,015	6,015	6,015
	External radius at bucket edge	R	mm	6,680	6,790	6,680	6,550	6,660	6,550	6,660	6,720
	Gradeability		% (°)	58 (30)							